



Isothermal container to transport and serve liquids, with 20 litre capacity

- Indicated for distribution of beverages (tea, coffee, milk, fruit juice, etc.) during breakfast, receptions, banqueting. The isothermal characteristics comply with current regulations (EC Reg. 852/2004 – HACCP-) and with applicable technical standards (EN 12571 and Accord AFNOR AC D40-007).
- Tap with rapid and precise dispenser.
- The container is light and easily stackable.
- Fitted with four support feet, to provide the container with excellent stability during transport..
- Thanks to its excellent isothermal characteristics, it keeps liquids at an optimum storage temperature for a long time.
- It assures proper temperature retention, limiting the risk of bacterial proliferation whilst preserving food quality and organoleptic characteristics.
- Designed to be long lasting: performance remains basically unaltered when reused.
- Fully recyclable at the end of the operating life.
- Produced with rotational moulding technology: the container and the lid have a monolithic structure (no sharp corners, junctions and welds).

MANUFACTURING MATERIALS

Polyethylene	inner and outer walls of the container and of the lid; food contact safe	Polyurethane	insulating material between the walls of the container and of the lid free of CFC and HCFC
Silicone rubber	gasket	Polyamide and Polypropylene	tap
Stainless steel	latches		

CHARACTERISTICS





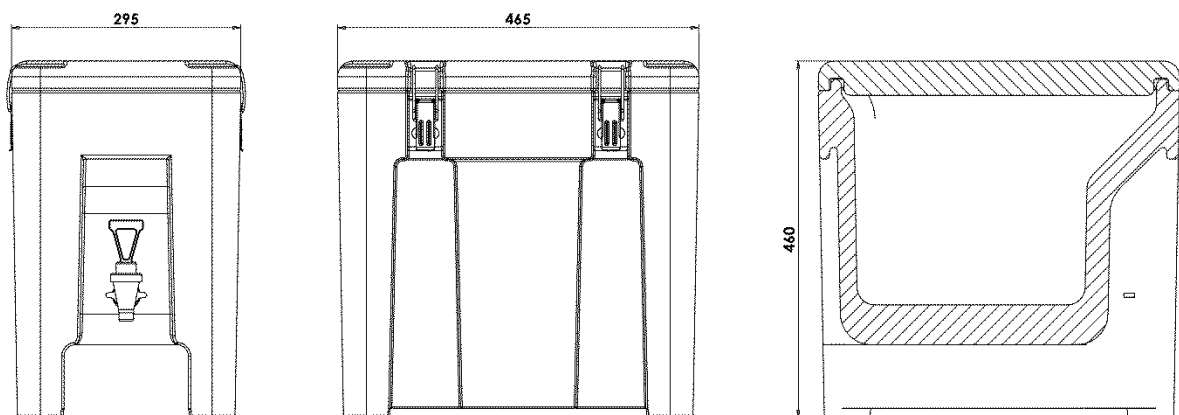

	<p>Space under the tap suitable to fill easily cups or bowls with maximum dimensions dia. 160 mm; height 94 mm, or dia. 120 mm; height 124 mm.</p>		<p>Available on request the long shank version, to allow the filling of bowls with diameter greater than 160mm</p>
	<p>The tap can be replaced with a blanking plug, useful during transport of liquid foods (broths, soups, etc.).</p>		<p>Wide top opening to ease filling operations.</p>
	<p>Melform closures in stainless steel.</p>		<p>Equipped with adjustable relief valve.</p>
	<p>Monolithic structure, no sharp corners, junctions and welds.</p>		<p>Easily removable lid gasket.</p>
	<p>Insulated with CFC and HCFC-free polyurethane foam.</p>	<p>°C</p>	<p>Container guaranteed for use: -30° to +85°C.</p>

TECHNICAL SPECIFICATIONS

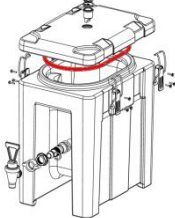
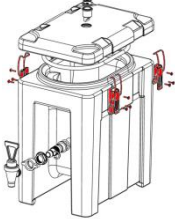
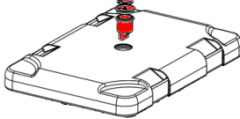
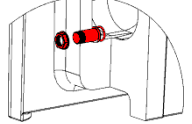

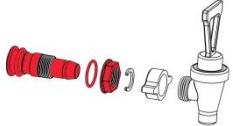
Model	Code	Colour	External dim. (mm)	Internal dim. (mm)	Capacity l	Weight Kg
QC20	QC200011	grey/blue mel.	295x465xh460		19	7.6
	QC200001	blue				
	QC200007	red				
	QC200003	sand				

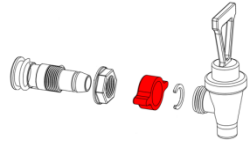
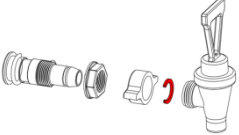
SPARE PARTS

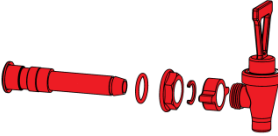
			
RRI022	RRI130	RRI031	RRI018
Gaskets kit	Stainless steel interlocking kit	Vent valves kit	Blanking plugs kit
5 pieces per package	4 pieces per package	10 pieces per package	1 piece per package
			
RRI011	RRI162	RRI012	RRI015
Complete tap kit	Shank kit (including nut and gasket)	Tap gaskets kit	Butterfly screws kit
1 piece per package	5 pieces per package	5 pieces of each gasket per package	5 pieces per package
			
RRI016	RRI063	RRI175	
Seeger kit	Gasket kit	Tap kit with long shank	
5 pieces per package	5 pieces per package	1 piece per package	